



CTS/ Small 3 Speed Circulation Pumps for Heading Systems

الکتروپمپ خطی (سیر کولاتور) سه سرعت مدل CTS تولید داخلی با برند ABR

مناسب برای سیستم های گرمایش خانگی سبک، قابل استفاده در
پکیج های حرارتی ساختمان

Model Instruction

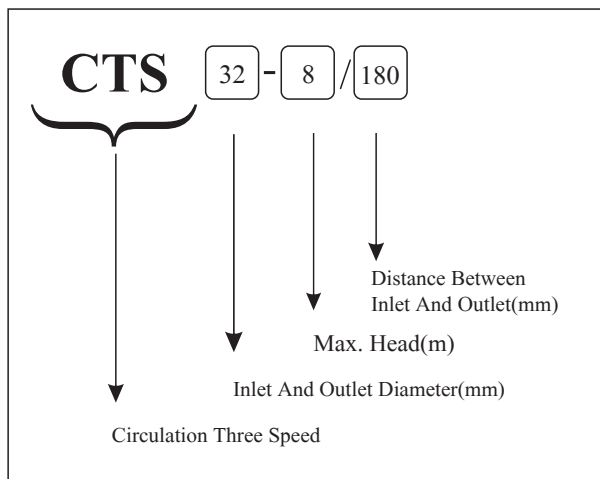

مشخصات سیال :	نوع سیال: حداکثر دما ۱۱۰°	آب تمیز
حداکثر فشار کاری (Bar) ۱۰		
اتصالات لوله:	فاصله بین ورودی و خروجی فاصله بین ورودی و خروجی	۱۳۰ میلیمتر (۱") ۱۸۰ میلیمتر (۱ ۱/۴" و ۱")
جنس:	پوستر پروانه شفاف	چدن تکنوپلیمر سرامیک



CTS/ Small 3 Speed Circulation Pumps for Heading Systems

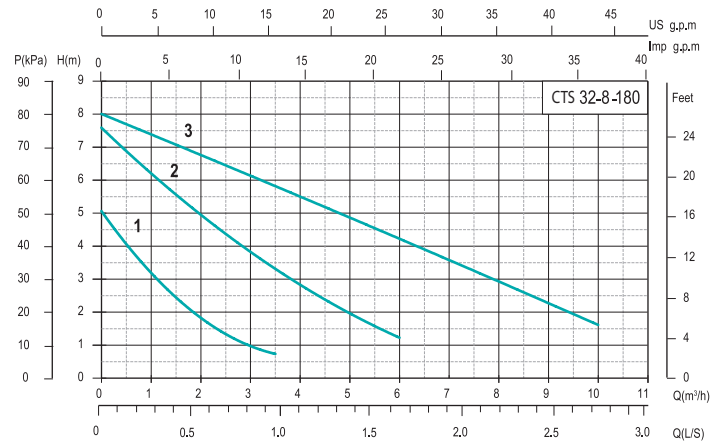
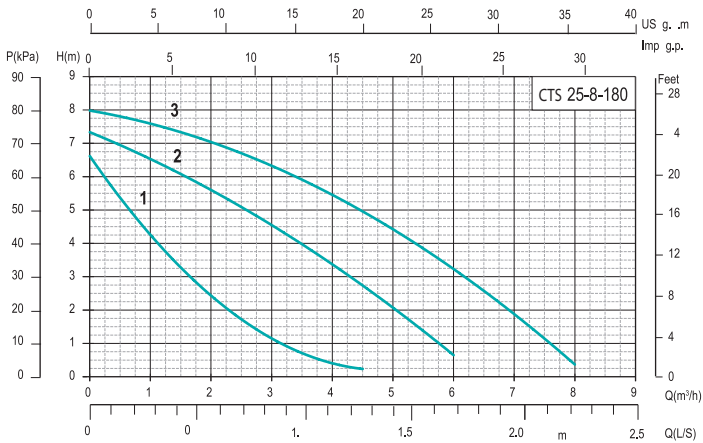
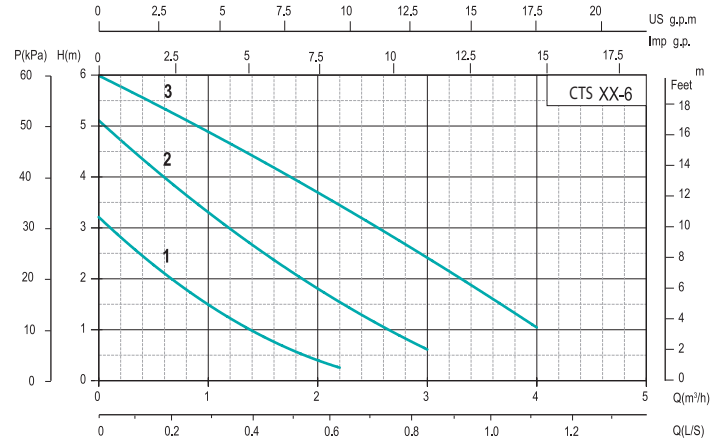
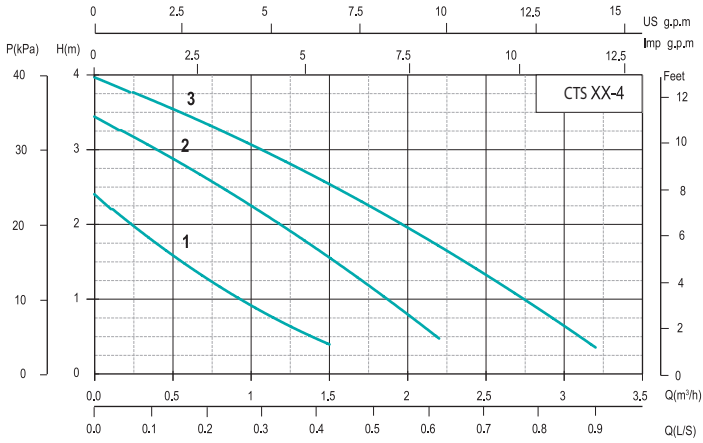



CTS/ Small 3 Speed Circulation Pumps for Heading Systems

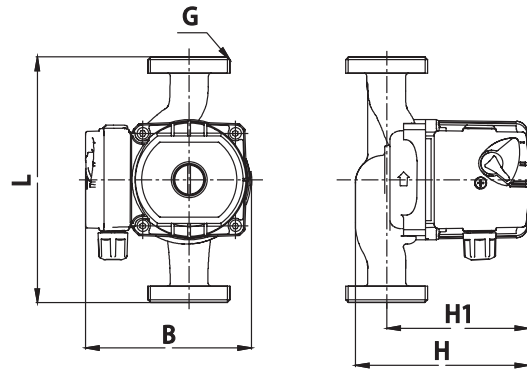
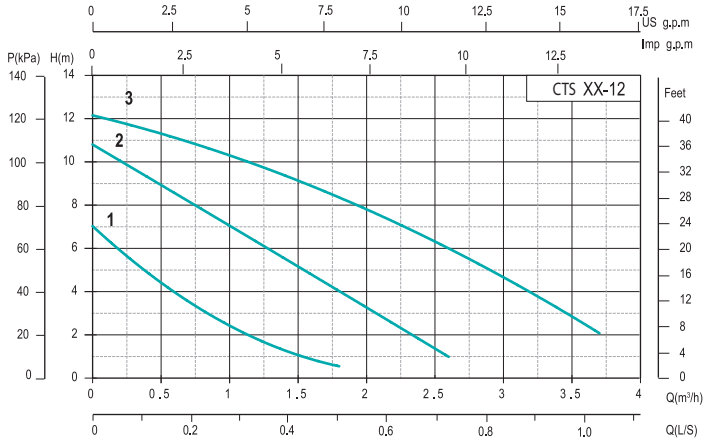

Model	Dim.(mm)										Unions or Flange	N.W (kg)
	H	H1	L	G	B	D1	D2	D3	D4			
CTS 25-4-130	125	105	130	G1½"	130	-	-	-	-	G1½"to G1"	2.8	
CTS 25-6-130												
CTS 25-4-180	125	105	180	G1½"	130	-	-	-	-	G1½"to G1"	3	
CTS 25-6-180												
CTS 32-4-180	130	105	180	G2"	130	-	-	-	-	G2"to G 1¼"	3.4	
CTS 32-6-180												
CTS 25-8-180	160	130	180	G1½"	150	-	-	-	-	G1½"to G1"	4.8	
CTS 25-12-180												
CTS 32-8-180	170	130	180	G2"	150	-	-	-	-	G2"to G 1¼"	5.2	



CTS/ Small 3 Speed Circulation Pumps for Heading Systems

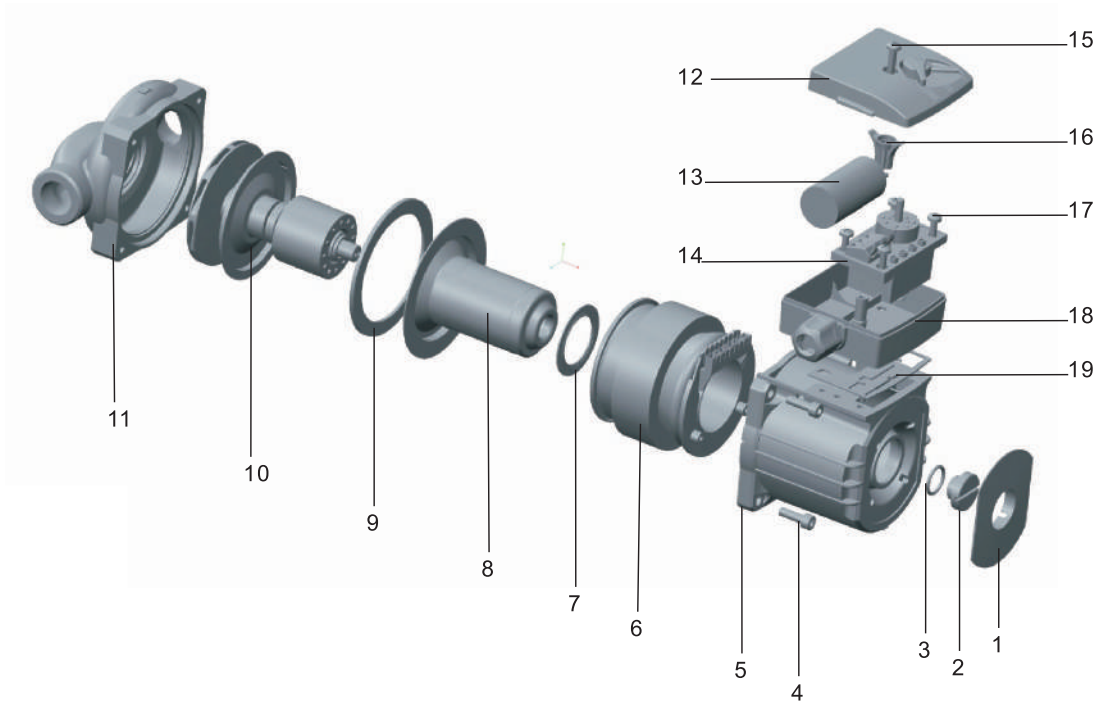

Pos.	Component	Material
1	Nameplate	PA6
2	Air Cock	Brass
3	O-ring	EPDM
4	Hex Socket Screws	Steel
5	Stator Housing	Aluminium
6	Stator	/
7	Sealing Ring II	EPDM
8	Rotor Can	Stainless steel
9	Sealing Ring I	EPDM
10	Impeller	PESG30
	Shaft	Ceramic
	Thrust Bearing	Graphite
	Radial Bearing	Ceramic
11	Pump Body	Cast iron
12	Terminal Box Cover	ABS
13	Capacitor	/
14	Circuit Board	/
15	Self-tapping Screw	Stainless steel
16	Capacitor Bracket	ABS
17	Screws	Steel
18	Terminal Box Base	PA66G30
19	Terminal Box Sealing Gasket	EPDM