



Single-impeller centrifugal pumps, extremely quiet, suitable for domestic, civil and industrial applications. The pumps guarantee constant pressure at the variation of flow rates.

Construction features

Pump body	cast iron
Motor bracket	cast iron (45, 50, 164÷550) aluminum (75÷100)
Impeller	Noryl® (45) Noryl® or brass (50÷314) brass (400-550)
Mechanical seal	ceramic-graphite-NBR
Motor shaft	stainless steel AISI 416 (45÷100) stainless steel AISI 303 (164÷550)
Liquid temperature	Noryl® impeller: 0 - 50 °C brass impeller: 0 - 90 °C
Operating pressure	max 6 bar (45÷100) max 8 bar (164÷550)

Motor

	3- 220/380V - 60Hz
2 Poles induction motor	1- 220V - 60Hz (with thermal protection up to MEC 80)
Insulation class	F
Protection degree	IPX4

1- 110V - 60Hz	
TYPE	I (A)
CM 45	5,4
CM 70	8,6
CM 50	6,4
CM 75	9,6
CM 100V	10,8
CM 100	12,2

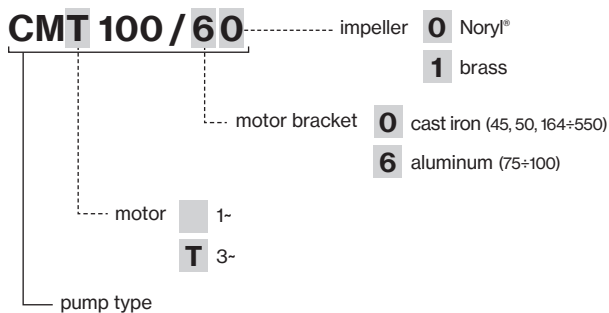

TYPE	LOTS			
	TRUCK		CONTAINER	
	PALLET (cm)	N° pumps	PALLET (cm)	N° pumps
CM(T) 45÷50	80×120×145	102	80×120×190	136
CM(T) 75÷100	85×110×145	65	85×110×195	91
CM(T) 164÷214	85×110×170	40	85×110×200	48
CM 314	85×110×150	24	85×110×180	30
CMT 314	85×110×170	40	85×110×200	48
CM(T) 400÷550	85×110×150	24	85×110×180	30

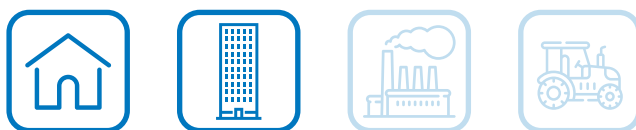

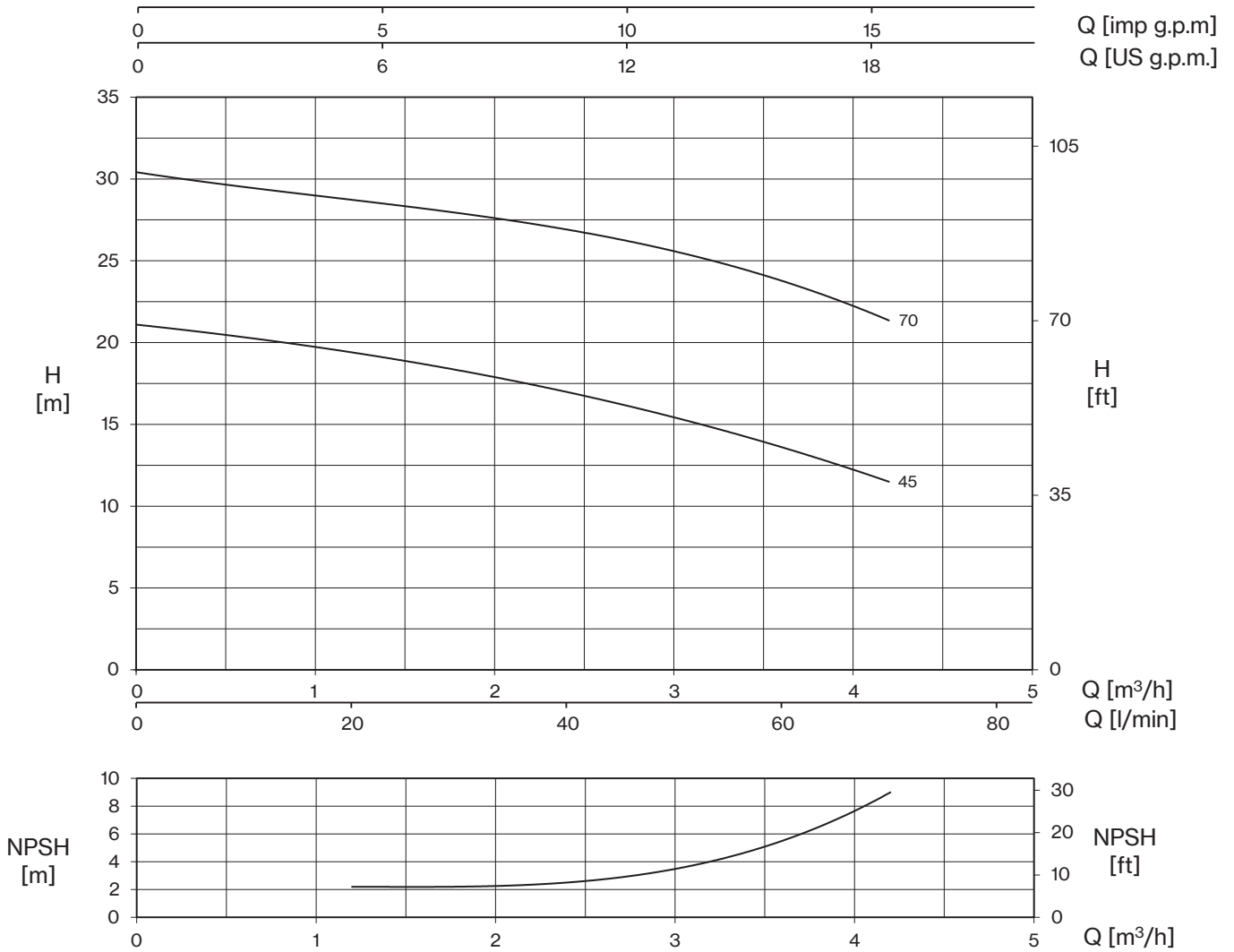

TYPE - 60 Hz		P2		P1		CURRENT		Q (m³/h - l/min)				
1~	3~			1~	3~	1~ 220V	3~ 380V	0	1,2	2,4	3,6	4,2
		HP	kW	kW		A		H (m)				
CM 45	CMT 45	0,4	0,3	0,57	0,62	2,7	1	21,1	19,4	17	13,6	11,5
CM 70	CMT 70	0,6	0,45	0,9	0,94	4,3	1,6	30,4	28,8	26,8	23,9	21,3

CM

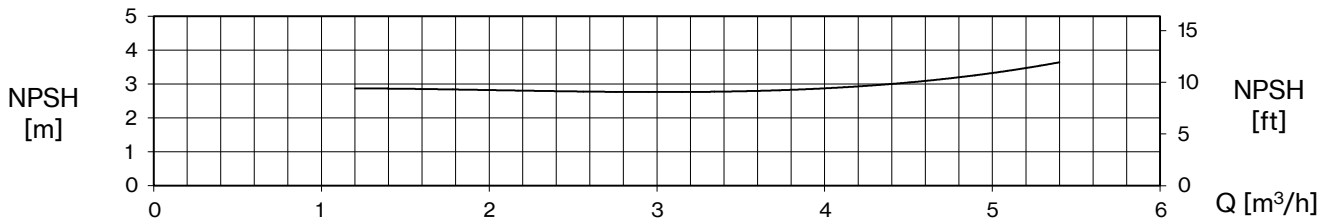
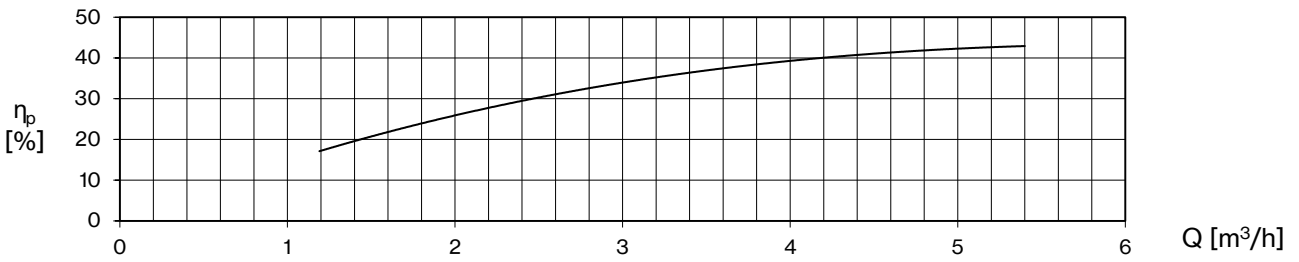
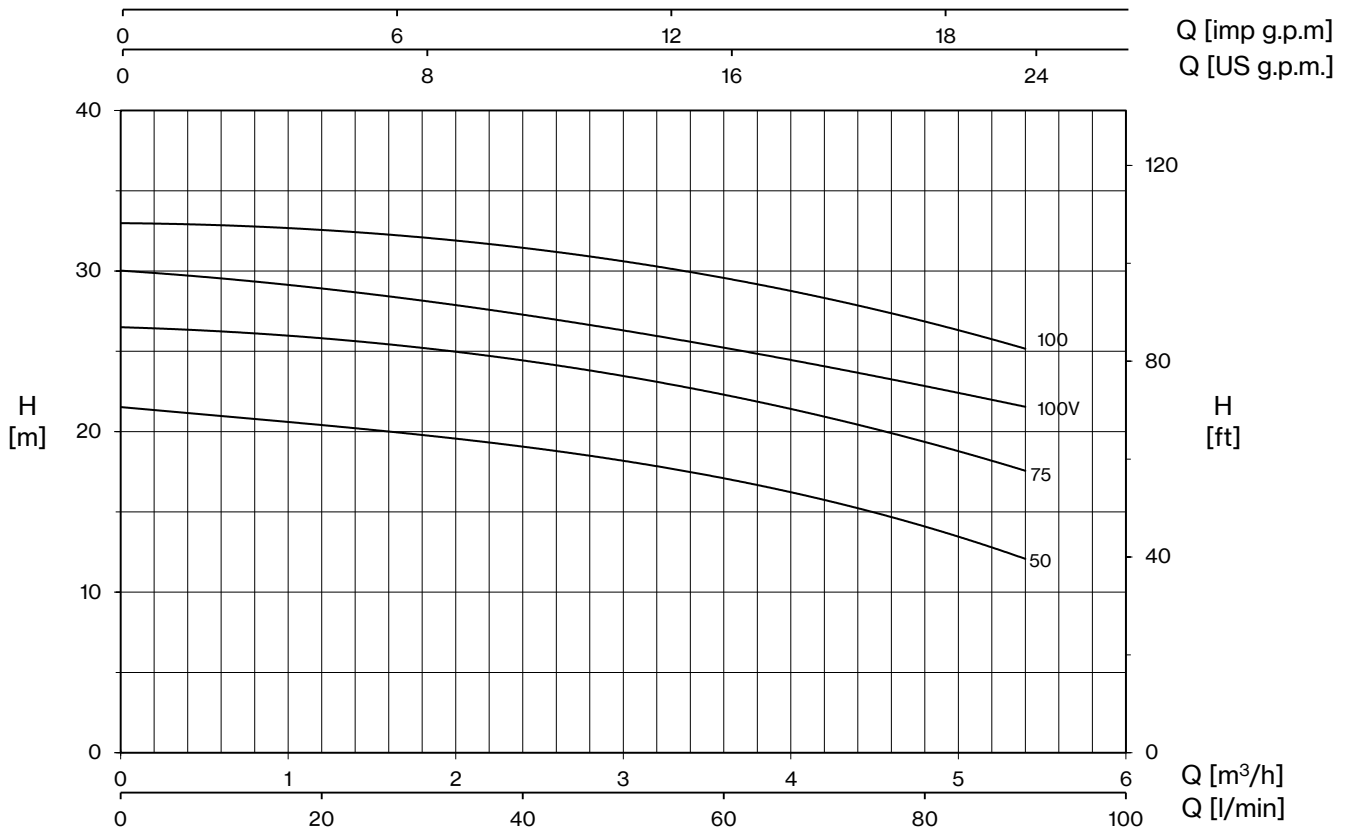

TYPE - 60 Hz		P2		P1		CURRENT		Q (m³/h - l/min)					
1-	3-			1-	3-	1- 220V	3- 380V	0	1,2	2,4	3,6	4,8	5,4
		HP	kW	kW		A		0	20	40	60	80	90
		H (m)											
CM 50	CMT 50	0,5	0,37	0,68	0,75	3,2	1,3	21,5	20,5	19,0	17,0	14,2	12,0
CM 75	CMT 75	0,8	0,59	0,98	1	4,8	1,8	26,5	25,8	24,5	22,2	19,5	17,5
CM 100 V	-	1	0,74	1,15	-	5,4	-	30,0	29,0	27,2	25,2	22,9	21,5
CM 100	CMT 100	1	0,74	1,3	1,33	6,1	2,2	33,0	32,5	31,5	29,6	26,8	25,2



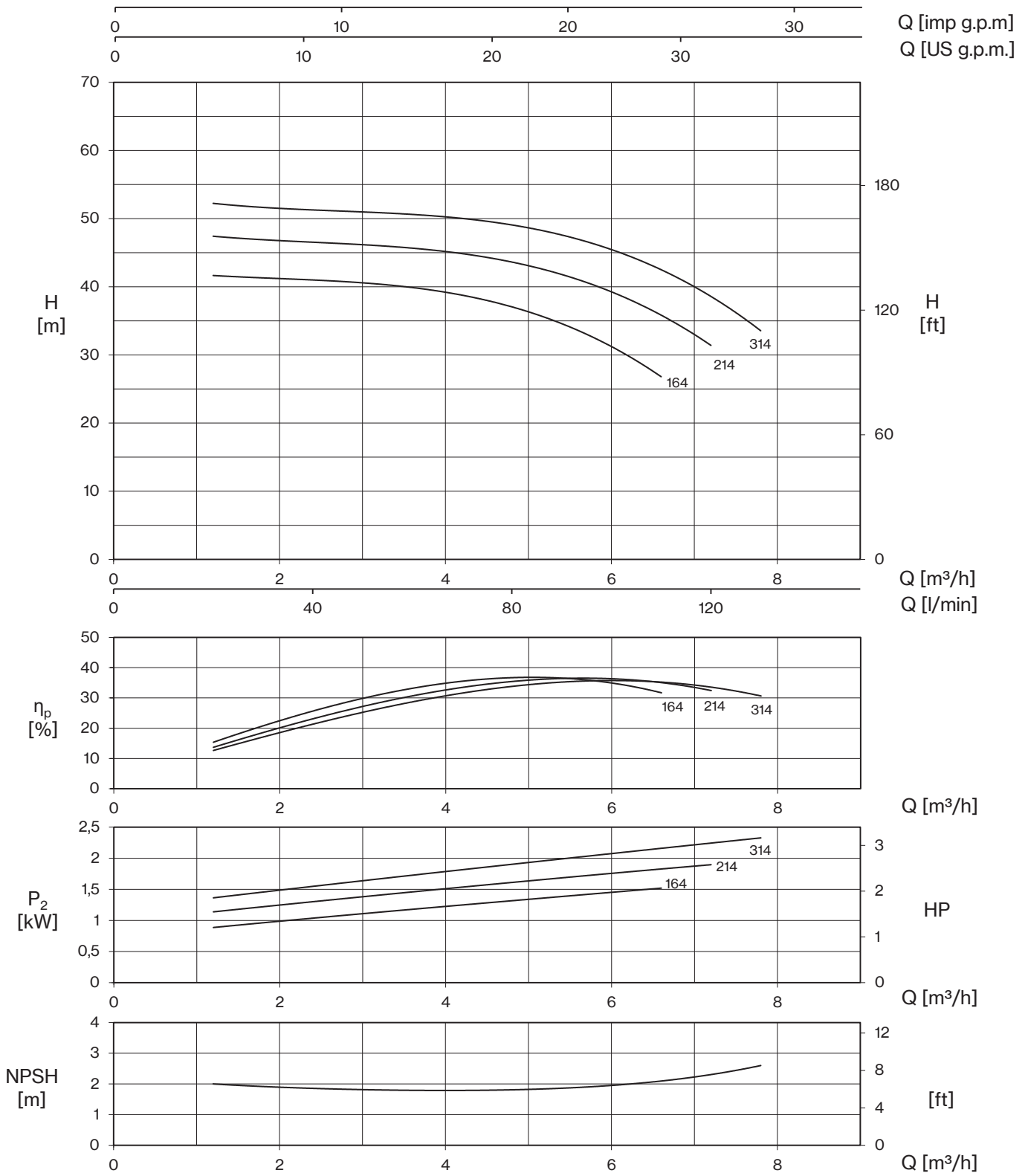

TYPE - 60 Hz		P2		P1		CURRENT		Q (m³/h - l/min)								
1-	3-			1-	3-	1- 220V	3- 380V	0	1,2	2,4	3,6	4,8	6	6,6	7,2	7,8
		HP	kW	kW		A		H (m)								
CM 164	CMT 164	2	1,5	1,9	1,8	8,9	3,8	41,8	41,6	41,1	39,7	37,3	31,1	26,9		
CM 214	CMT 214	2,5	1,84	2,3	2,2	10,8	4,4	47,6	47,3	46,8	45,5	43,4	39,6	35,7	31,3	
CM 314	CMT 314	3	2,2	2,8	2,5	14,8	5,1	52,3	52,1	51,7	50,5	48,5	45,9	42,7	38,4	33,5



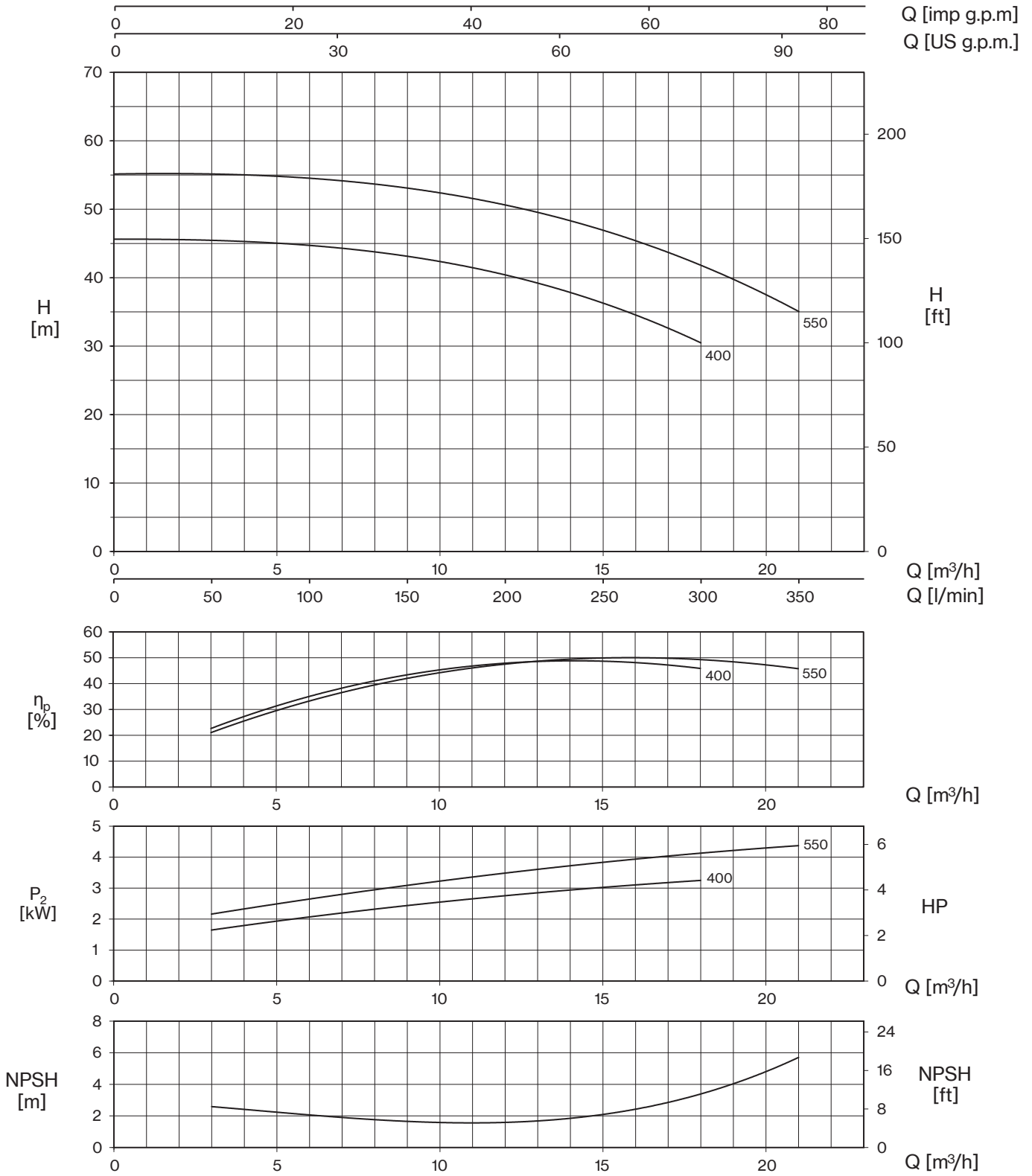

CM



TYPE - 60 Hz		P2		P1		CURRENT		Q (m³/h - l/min)							
1~	3~			1~	3~	1~ 220V	3~ 380V	0	3	6	9	12	15	18	21
		HP	kW	kW		A		H (m)							
CM 400	CMT 400	4	3	3,7	3,7	17,6	7	45,6	45,4	44,9	43	40,3	36,4	30,4	
-	CMT 550	5,5	4	-	5,0	-	9,4	55,1	55,1	54,7	53,1	50,3	47	42	34,9

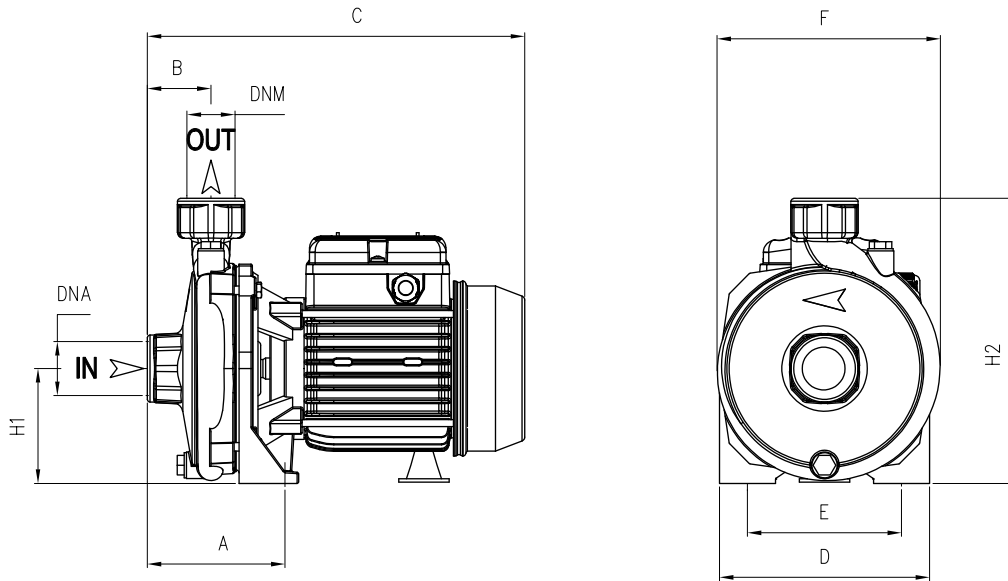



TYPE		DIMENSIONS (mm)													 Kg	
1-	3-	A	B	C	D	E	F	H1	H2	DNA	DNM	I	L	M	1-	3-
CM 45	CMT 45	95	45,5	265	150	110	160	82	202	1" G	1" G	290	175	225	8,5	8,5
CM 70	CMT 70	95	45,5	265	150	110	160	82	202			290	170	230	10	10
CM 50	CMT 50	95	45,5	265	150	110	160	82	202	1" G	1" G	290	175	225	9,5	9,5
CM 75	CMT 75	110	46,5	300	180	140	185	97	234			325	200	265	13,5	13
CM 100 V	-	110	46,5	300	180	140	185	97	234			325	200	265	14	-
CM 100	CMT 100	110	46,5	300	180	140	185	97	234			325	200	265	15	14,5
CM 164	CMT 164	117	46,5	378	220	180	225	115	285	1" ¼ G	1" G	420	230	309	24	26,5
CM 214	CMT 214	117	46,5	378	220	180	225	115	285			420	230	309	26	25,5
CM 314	-	117	46,5	446	220	180	225	115	285			520	235	320	34	-
-	CMT 314	117	46,5	378	220	180	225	115	285			420	230	309	-	26,5
CM 400	CMT 400	108	54	460	240	190	250	133	323	2" G	1" ¼ G	480	255	342	45,5	41
-	CMT 550	108	54	460	240	190	250	133	323			480	255	342	45,5	45,5