



Twin-impeller centrifugal pumps for pressurisation systems in civil and industrial applications; the dual impellers ensure high head and flow rate.

Construction features

Pump body	cast iron
Motor bracket	cast iron
Impeller	brass or Noryl® (100÷900) brass (800÷1500)
Mechanical seal	ceramic-graphite-NBR
Motor shaft	stainless steel AISI 303 stainless steel AISI 416 (100)
Liquid temperature	Noryl® impeller: 0 - 50 °C brass impeller: 0 - 90 °C
Operating pressure	max 6 bar (100) max 11 bar (160÷1500)

Motor

	3- 220/380V - 60Hz
2 Poles induction motor	1- 220V - 60Hz (with thermal protection up to MEC 80)
Insulation class	F
Protection degree	IPX4 IPX5 (800÷1500)

1- 110V - 60Hz	
TYPE	I (A)
CB 100	10,8

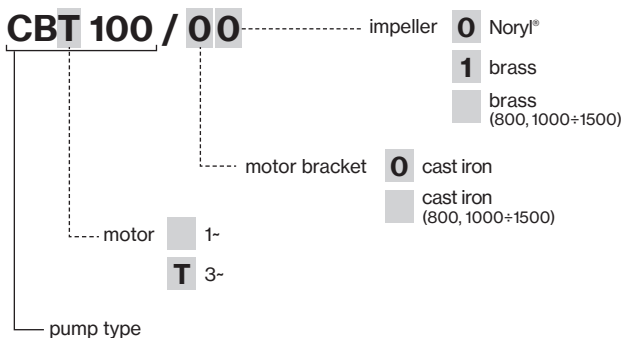

TYPE	LOTS			
	TRUCK		CONTAINER	
	PALLET (cm)	N° pumps	PALLET (cm)	N° pumps
CB 100	90×110×145	65	90×110×195	91
CB 160÷CBT 310	85×110×130	40	85×110×190	60
CB 310	85×110×150	24	85×110×180	30
CB 400÷900	80×120×150	24	80×120×180	30
CBT 800÷1500	100×120×140	18	100×120×185	24

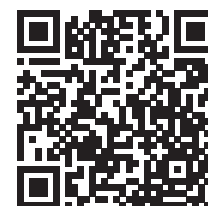
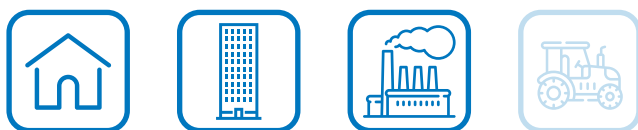

CB

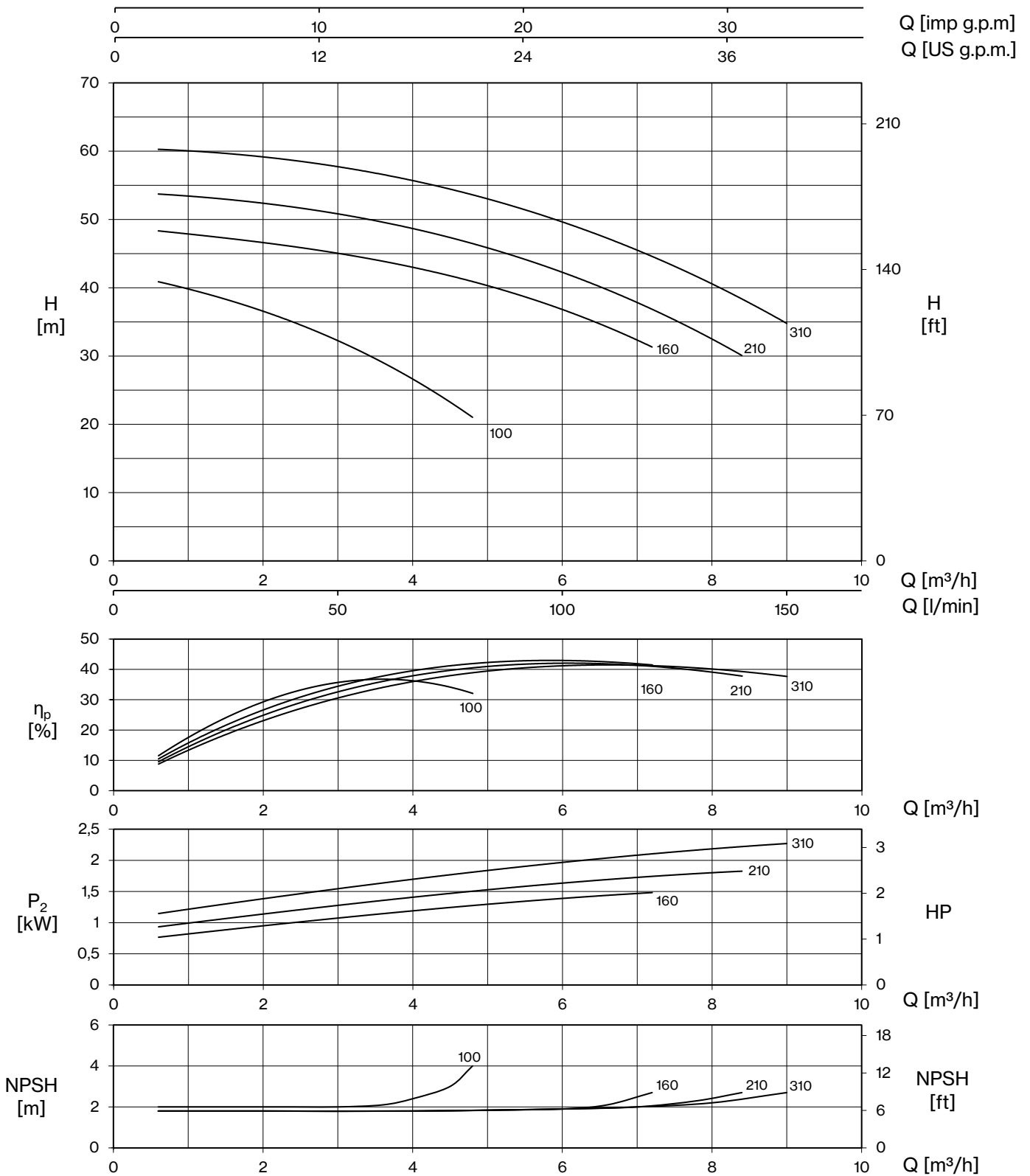

TYPE - 60 Hz		P2		P1		CURRENT		Q (m³/h - l/min)														
1-	3-			1-	3-	1- 220V	3- 380V	0	0,6	1,2	1,8	2,4	3,6	4,8	6	7,2	8,4	9				
		HP	kW	kW		A		H (m)														
CB 100	CBT 100	1	0,74	1,17	1,15	5,4	2,4	42,0	40,8	39,4	37,4	34,7	29,2	21,0								
CB 160	CBT 160	2	1,5	1,9	1,8	8,9	3,8	49,0	48,4	47,6	46,9	46,0	44,0	40,9	36,8	31,3						
CB 210	CBT 210	2,5	1,84	2,3	2,2	10,8	4,4	54,6	53,9	53,2	52,5	51,6	49,8	46,6	42,2	36,6	30,2					
CB 310	CBT 310	3	2,2	2,8	2,5	14,8	5,1	61,0	60,4	59,8	59,3	58,7	56,8	53,5	49,6	44,6	38,3	34,8				



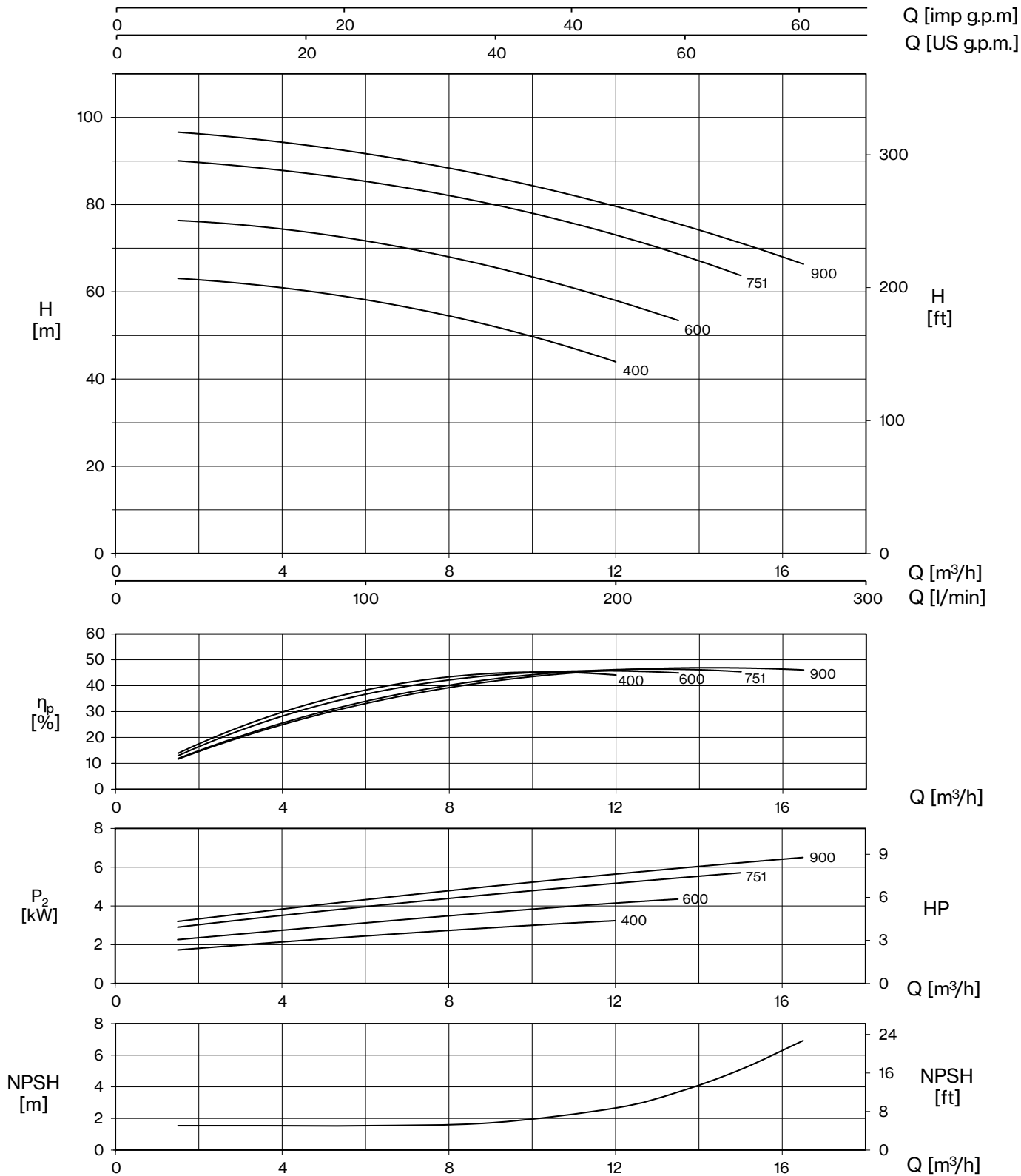



TYPE - 60 Hz		P2		P1		CURRENT		Q (m³/h - l/min)															
1-	3-							1-	3-	1- 220V	3- 380V	0	1,5	3	4,5	6	7,5	9	10,5	12	13,5	15	16,5
		HP	kW	kW		A		H (m)															
CB 400	CBT 400	4	3	3,7	3,8	17,7	7,1	64,2	64,1	63,3	61,9	59,9	57,4	54,3	50,4	45,6							
CB 600	CBT 600	5,5	4	5,2	4,9	24,5	9,4	76,9	76,8	76,1	74,7	72,7	69,9	66,6	62,5	58,2	53,7						
-	CBT 751	7,5	5,5	-	6,5	-	12,1	92,9	92,7	91,8	90,4	88,5	85,9	82,8	79,0	74,7	69,9	64,4					
-	CBT 900	10	7,5	-	7,4	-	14,2	98,0	97,7	96,8	95,4	93,4	90,9	87,8	84,2	80,0	75,2	70,1	65,1				

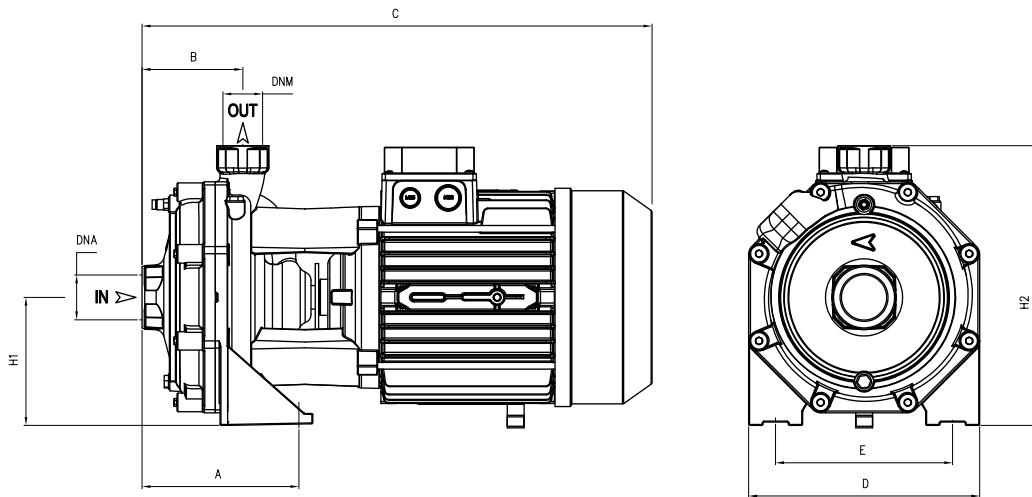



TYPE		DIMENSIONS (mm)													
1-	3-	A	B	C	D	E	H1	H2	DNA	DNM	I	L	M	1-	3-
CB 100	CBT 100	122	72	328	180	140	98	228	1" G	1" G	350	195	265	15,5	15
CB 160	CBT 160	115	82	408	210	170	110	265	1" 1/4 G		433	220	287	25	26
CB 210	CBT 210	115	82	408	210	170	110	265			433	220	287	25,5	26,5
CB 310	-	115	82	477	210	170	110	265			520	235	320	35	-
-	CBT 310	115	82	408	210	170	110	265		433	220	287	-	26	
CB 400	CBT 400	145	95,5	498	266	212	135	305	1" 1/2 G	1" 1/4 G	553	274	318	48	44
CB 600	CBT 600	145	95,5	498	266	212	135	305			553	274	318	56,5	48
-	CBT 751	145	95,5	532	266	212	135	305			553	274	318	-	56
-	CBT 900	145	95,5	532	266	212	135	305			553	274	318	-	62
-	CBT 800	190	120	605	275	210	150	330	2" G	1" 1/4 G	675	390	300	-	77
-	CBT 1000	190	120	605	275	210	150	330			675	390	300	-	83
-	CBT 1250	190	120	645	275	210	150	330			675	390	300	-	91
-	CBT 1500	190	120	645	275	210	150	330			675	390	300	-	94,5