

Self-priming centrifugal pump for water supplies (even if mixed with gas) in small household systems, connected to autoclave tanks, for transferring liquids and emptying tanks; also used for gardening.



CAM 50N÷140



CAM 150÷300



1~ 110V - 60Hz	
TYPE	I (A)
CAM 50	6,4
CAM 75	7,4
CAM 100N	10,2
CAM 120	10,8

Construction features

Pump body	cast iron
Motor bracket	aluminum (50N÷140) cast iron (150÷300)
Impeller	Noryl®, brass
Mechanical seal	ceramic-graphite-NBR
Motor shaft	stainless steel AISI 416
Liquid temperature	0 - 50 °C
Operating pressure	max 6 bar (50N÷75N) max 7 bar (100N÷140) max 8 bar (150÷300)

Motor

2 Poles induction motor	3~ 220/380V - 60Hz 1- 220V - 60Hz (with thermal protection)
Insulation class	F
Protection degree	IPX4

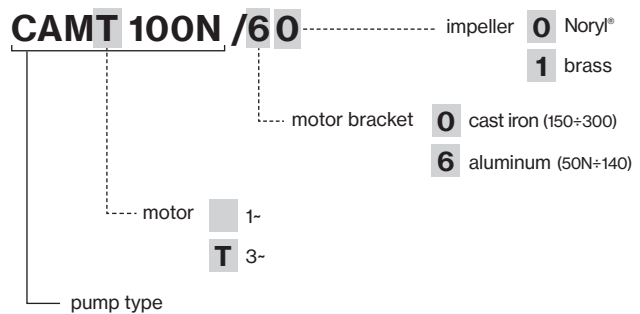
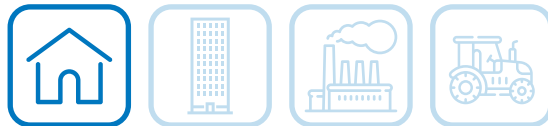

TYPE	LOTS			
	TRUCK		CONTAINER	
	PALLET (cm)	N° pumps	PALLET (cm)	N° pumps
CAM(T) 50N÷140	85×110×145	60	85×110×190	80
CAM(T) 150÷200	80×120×140	25	80×120×180	35
CAM 300	85×110×145	20	85×110×170	24
CAMT 300	80×120×140	25	80×120×180	35

CAM

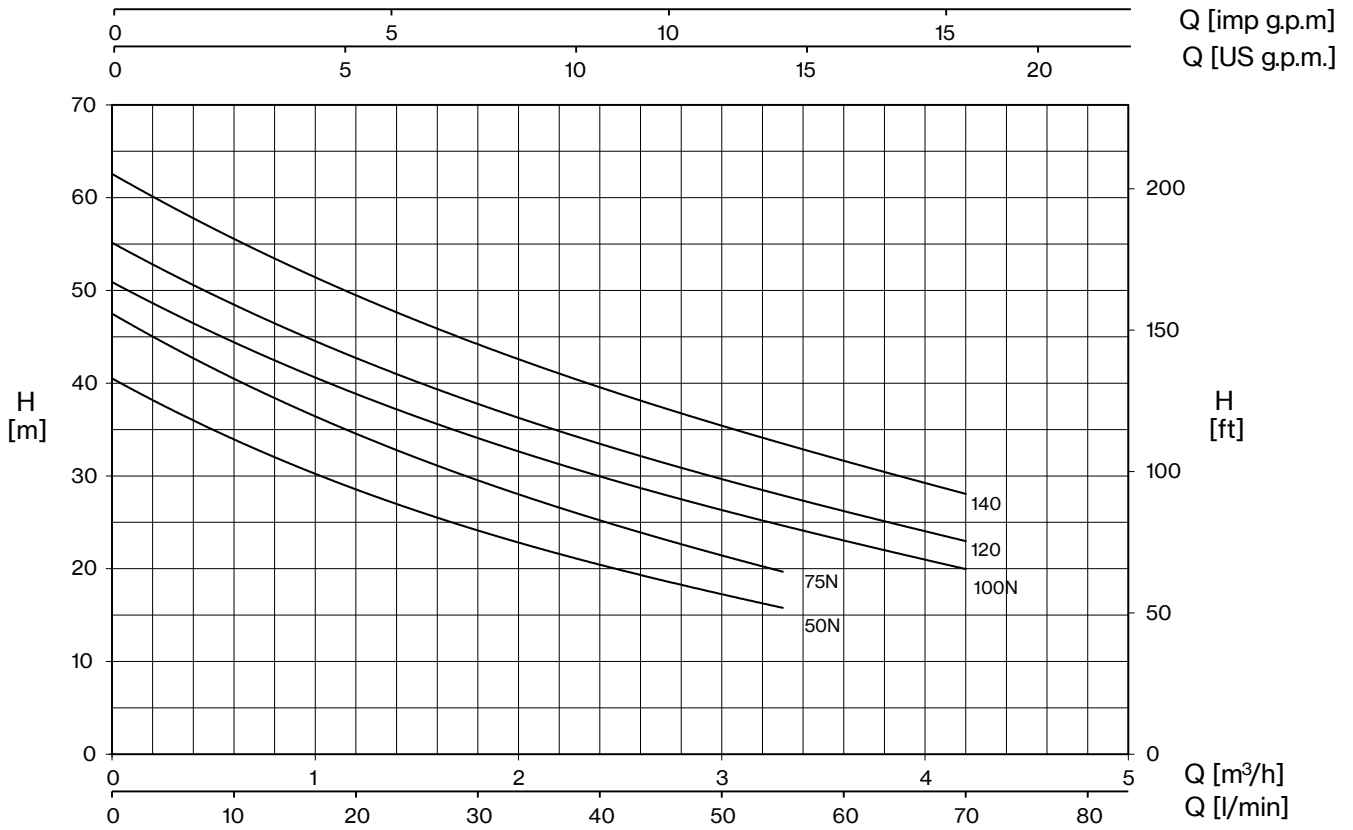

TYPE - 60 Hz		P2		P1		CURRENT		Q (m³/h - l/min)									
1~	3~			1~	3~	1~ 220V	3~ 380V	0	0,6	1,2	1,8	2,4	3	3,3	3,6	4,2	
		HP	kW	kW		A		H (m)									
CAM 50N	CAMT 50N	0,6	0,44	0,7	0,67	3,2	1,4	40,5	34,0	28,5	24,1	20,5	17,2	15,8			
CAM 75N	CAMT 75N	0,8	0,59	0,82	0,78	3,7	1,5	47,5	40,5	34,5	29,6	25,2	21,4	19,7			
CAM 100N	CAMT 100N	1	0,74	1,04	0,92	5,1	1,7	50,9	44,3	38,9	34,1	30,1	26,3	24,6	23,0	20,0	
CAM 120	CAMT 120	1,2	0,88	1,14	1,07	5,4	1,9	55,1	48,5	42,6	37,8	33,5	29,7	27,9	26,2	23,0	
CAM 140	CAMT 140	1,5	1,1	1,3	1,25	6,6	2,5	62,5	55,7	49,4	44,2	39,5	35,5	33,5	31,6	28,1	



CAM

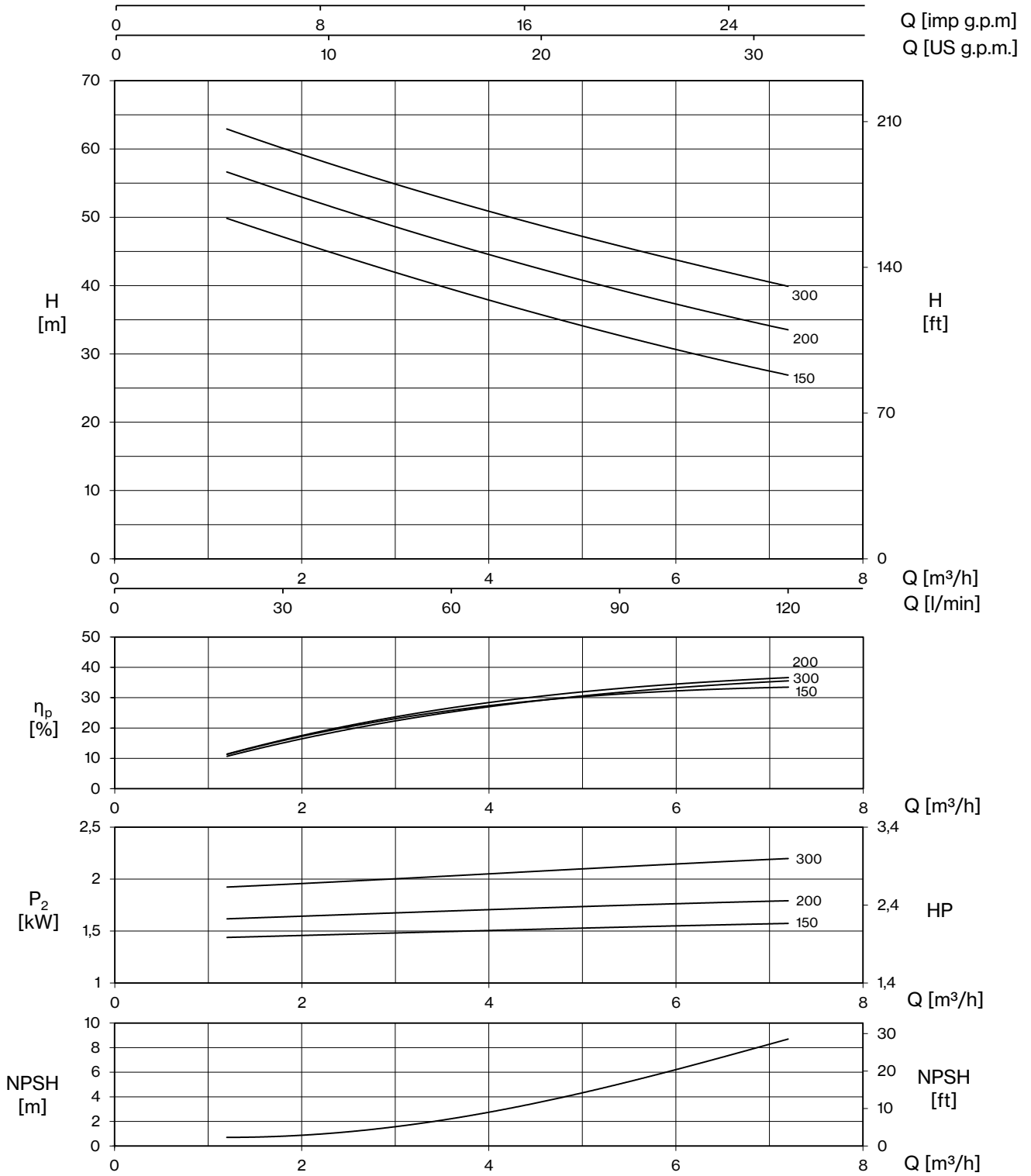

TYPE - 60 Hz		P2		P1		CURRENT		Q (m³/h - l/min)						
1~	3~			1~	3~	1~ 220V	3~ 380V	0	1,2	2,4	3,6	4,8	6	7,2
		HP	kW	kW		A		0	20	40	60	80	100	120
		H (m)												
CAM 150	CAMT 150	2	1,5	1,9	1,8	8,9	3,8	55,8	49,9	44,4	39,5	34,9	30,6	26,9
CAM 200	CAMT 200	2,5	1,84	2,2	2,1	10,4	4,3	62,4	56,7	51,2	46,2	41,6	37,3	33,5
CAM 300	CAMT 300	3	2,2	2,7	2,5	14,1	5,1	68,9	62,9	57,4	52,5	48,0	43,7	39,9



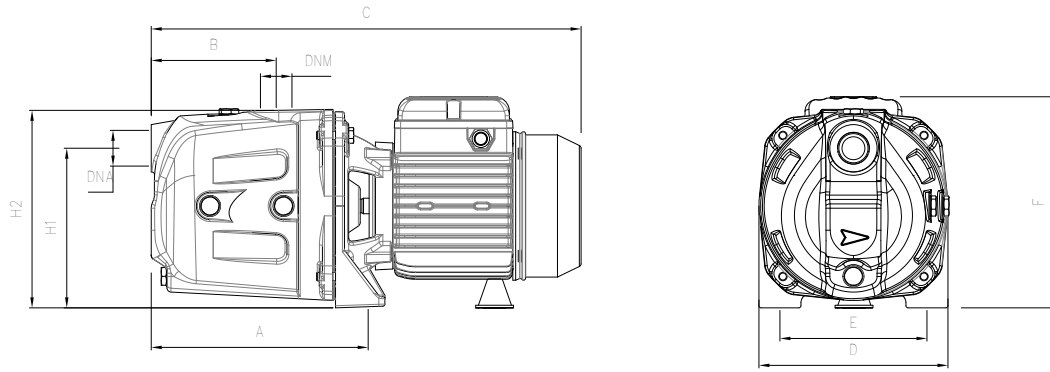

TYPE		DIMENSIONS (mm)													
1~	3~	A	B	C	D	E	F	H1	H2	DNA	DNM	I	L	M	Kg
CAM 50N	CAMT 50N	214	119	410	180	140	195	150	185	1" G	1" G	440	194	215	
CAM 75N	CAMT 75N	214	119	410	180	140	195	150	185			440	194	215	12,5
CAM 100N	CAMT 100N	214	119	410	180	140	195	150	185			440	194	215	14
CAM 120	CAMT 120	214	119	410	180	140	195	150	185			440	194	215	14,5
CAM 140	CAMT 140	214	119	410	180	140	195	150	185			440	194	215	15

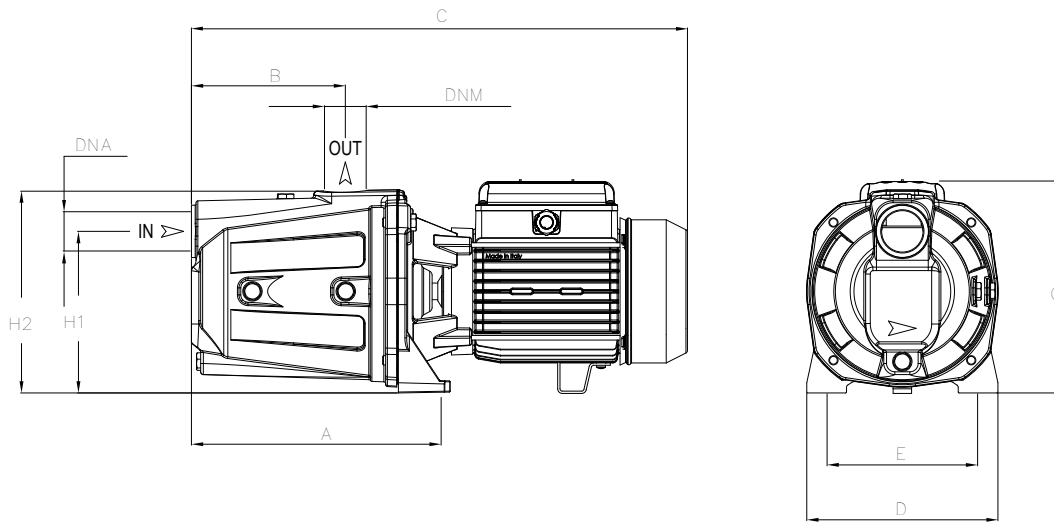

TYPE		DIMENSIONS (mm)														
1~	3~	A	B	C	D	E	G	H1	H2	DNA	DNM	I	L	M	-1	-3
CAM 150	CAMT 150	269,6	167	538	203	165	231,5	175	220	1" ½ G	1" ¼ G	565	235	232	29	30,5
CAM 200	CAMT 200	269,6	167	538	203	165	231,5	175	220			565	235	232	30	29,5
CAM 300	-	269,6	167	608	203	165	231,5	175	220			638	230	255	37,5	-
-	CAMT 300	269,6	167	538	203	165	231,5	175	220			565	235	232	-	30

CAM GARDEN

Portable electropumps complete with handle, cable with plug and switch.
The performances depend on adopted pump type.

TYPE - 60 Hz	P2		P1	Pipe		Performance	
	HP	kW	kW	Suction	Delivery	Q (l/min)	H (m)
CAM 50N GARDEN	0,6	0,44	0,7	1	1	10-55	34,0-15,8
CAM 75N GARDEN	0,8	0,59	0,82	1	1	10-55	40,5-19,7
CAM 100N GARDEN	1	0,74	1,06	1	1	10-70	44,3-20,0
CAM 120 GARDEN	1,2	0,88	1,14	1	1	10-70	48,5-23
CAM 140 GARDEN	1,5	1,1	1,3	1	1	10-70	55,7-28,1

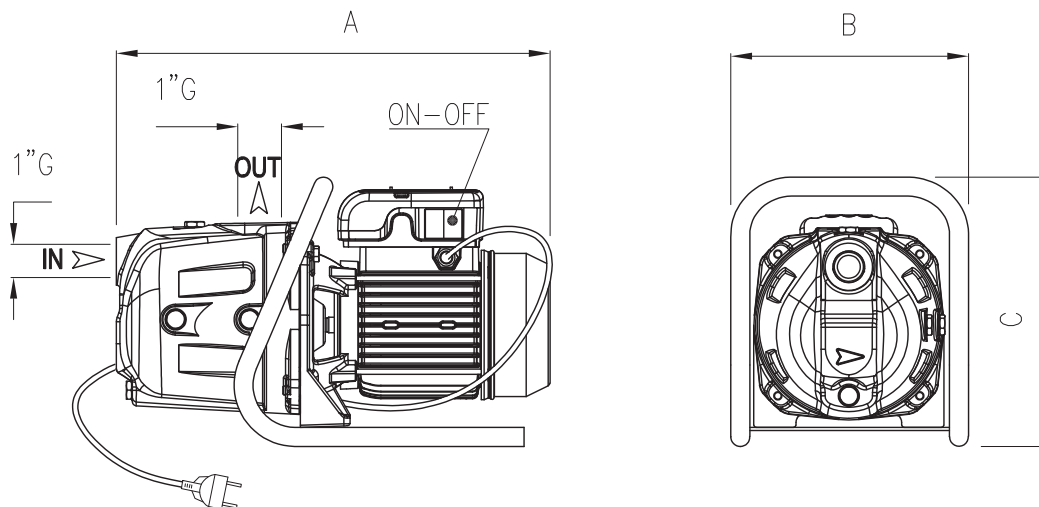

TYPE	DIMENSIONS (mm)		
	A	B	C
CAM 50N GARDEN	410	266	252
CAM 75N GARDEN	410	266	252
CAM 100N GARDEN	410	266	252
CAM 120 GARDEN	410	266	252
CAM 140 GARDEN	410	266	252

